

2128 Air Compressor Pump

Fitting Instructions for Dry-Pac Kit Z2128-670

Kit Z2128-670

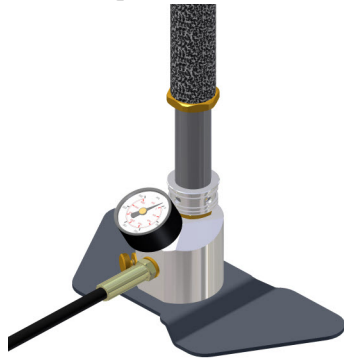

Pump before attachment of Dry-Pac kit.

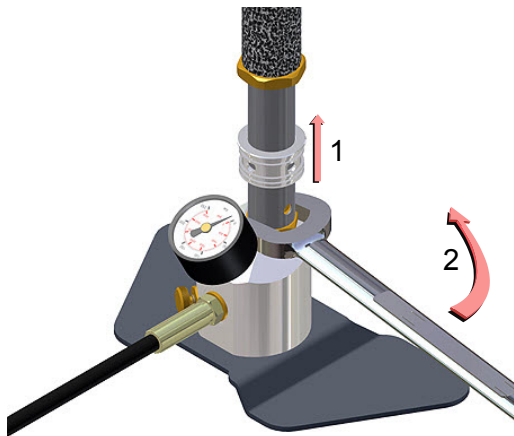

- 1 Slide aluminium sleeve away from pump base to allow spanner access.
- 2 With suitable size spanner, unscrew pump cylinder from base.



withdraw pump cylinder from base

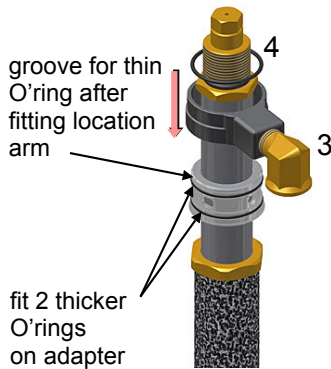

- 3 Slide location arm over aluminium sleeve. It is correctly fitted when the letter T is facing the handle and the arm is in contact with the stop on the sleeve with the groove visible above the location arm.
- 4 Locate thin O-ring in groove on sleeve to lock the location arm in position.



groove for thin O-ring after fitting location arm

fit 2 thicker O-rings on adapter ring in the grooves on each side of the bored recess

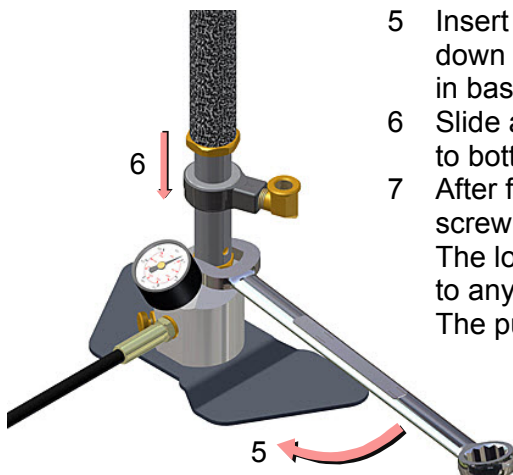

- 5 Insert pump cylinder into base and screw down fully (take care not to damage thread in base)
- 6 Slide assembled sleeve and location arm to bottom of cylinder
- 7 After filling Dry-Pac cartridge (see over) screw this onto brass fitting and tighten. The location arm can be swung around to any desired position. The pump is now ready for use.

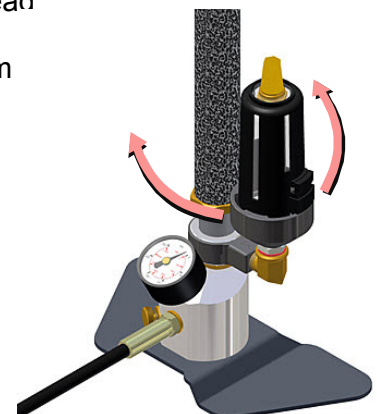

DRY-PAC Patented Dry Air Flow System

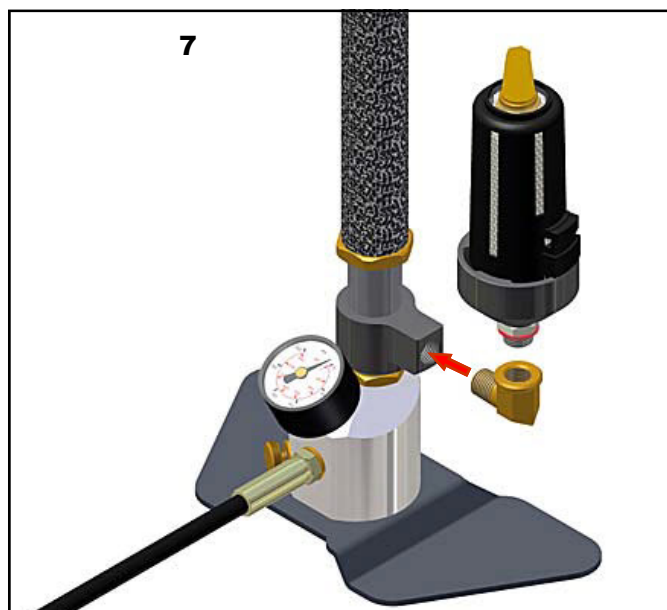
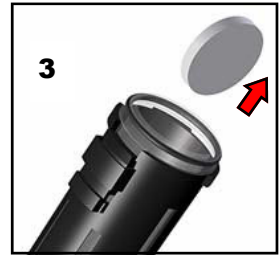

Ernest H. Hill Ltd
SHEFFIELD - ENGLAND
www.airriflepump.com