



Made in
Britain

ERNEST H. HILL LTD • SHEFFIELD
www.hillpumps.com

USER INSTRUCTION MANUAL



EC3000 PORTABLE AIR COMPRESSOR

Contents

Parts Included.....	3
Set Up.....	4-6
Operating Instructions:	
Connecting to a vessel.....	6
Switching on power.....	7
Setting target pressure.....	7
Starting a fill.....	8
Pausing a fill.....	9
Auto Cooling.....	9
Auto Cut-Off & Depressurisation.....	
Lubrication check timeout.....	10
Setting units of pressure.....	11
Trimming calibration.....	12
Troubleshooting.....	13
Closedown.....	13
Storage.....	13
Maintenance.....	13



IMPORTANT

THIS PRODUCT IS DESIGNED TO **FILL** PRE-CHARGED PCP AIR GUNS AND PAINTBALL GUNS DIRECTLY. IT CAN ALSO BE USED TO **TOP UP** SMALL BOTTLES. LARGE CYLINDERS/TANKS SHOULD ONLY BE FILLED BY COMPETENT/QUALIFIED PEOPLE.

NOT FOLLOWING THE INSTRUCTIONS OR MISUSE OF THE COMPRESSOR WILL VOID YOUR WARRANTY AND MAY RESULT IN DEATH OR INJURY



DANGER

DANGER OF EXPLOSION

FROM OVERFILLING OF COMPRESSED AIR BOTTLES



DO NOT EXCEED MAXIMUM FILL PRESSURE OF YOUR BOTTLE AT ROOM TEMPERATURE. ONLY FILL BOTTLES THAT ARE IN GOOD CONDITION AND ARE IN DATE OF INSPECTION.



IMPORTANT

READ ALL INSTRUCTIONS BEFORE USE.
TO PROTECT YOURSELF YOU SHOULD ALWAYS WEAR SAFETY GLASSES AND EAR PLUGS WHEN OPERATING THIS COMPRESSOR



WARNING

THIS COMPRESSOR PRODUCES CLEAN AIR SUITABLE FOR FILLING PCP AIRGUNS. IT DOES NOT PRODUCE AIR SUITABLE OR CERTIFIED FOR BREATHING APPARATUS DO NOT USE IT TO FILL SCUBA TANKS THAT MAY LATER BE USED FOR BREATHING.

Parts Included

1x EC-3000 Compressor

1x Power Cable

1x High Pressure Filling Hose 1/8" and male Quick Release Coupling

1x Hill A73 Crank Oil

1x Hill A72 Silicone Oil

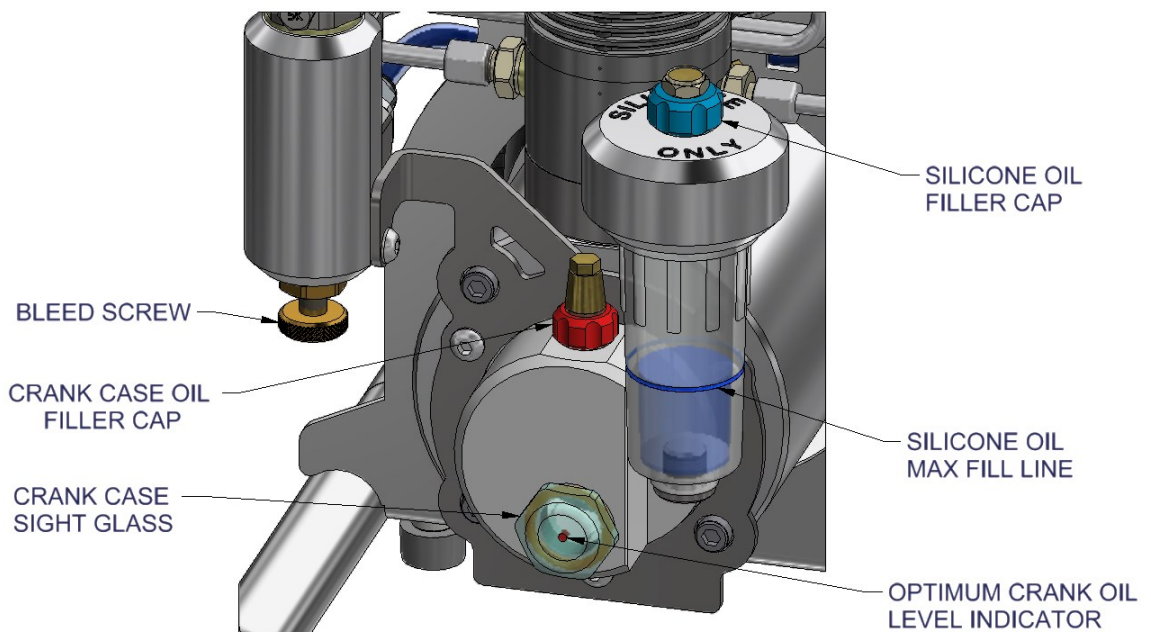
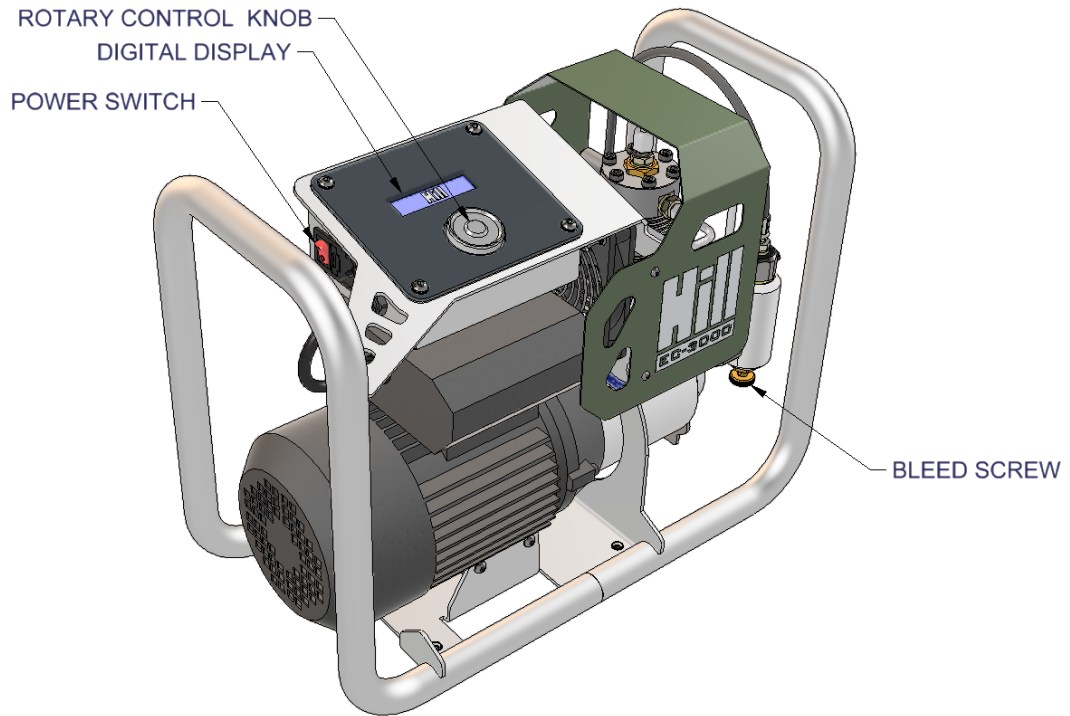

SET UP

CAUTION - Please read and understand the following instructions before use.

CAUTION - Once the compressor has been correctly filled with lubricants, the compressor must be kept upright at all times. Ensure the compressor is used on an anti-slip floor, preferably placed on anti-slip matting.

1) Crank Oil Level

With the compressor positioned on a level surface, check that the oil level meets the red dot on the sight glass.

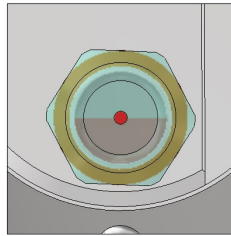

Top up as necessary as per the following procedure:

- Ensure the correct oil type is used.



- Remove red crank case cap by unscrewing (anti-clockwise).
- Slowly squeeze the Hill A73 crank oil into the exposed hole until the lubricant level meets the red dot in the sight glass. This should approximately use a full bottle (50ml).
- Replace the red cap finger tight (clockwise).

DO NOT MIX CRANK OIL AND SILICONE OIL
DO NOT OVERFILL



After an oil change or fill, leave the oil to settle for 5 mins, if the oil level drops below the red dot, top up with more oil until the level is maintained.

2) Silicone Oil Level

Top up the silicone oil reservoir as per the following procedure:

- Ensure the correct oil type is used.



- Remove silicone oil reservoir blue cap by unscrewing (anti-clockwise).



- Slowly squeeze the Hill A72 silicone oil into the exposed hole until the lubricant level meets the blue max level line indicated on the reservoir. Ensure that the silicone oil uptake straw is submerged in the reservoir.



- Replace the blue cap finger tight (clockwise).

DO NOT MIX CRANK OIL AND SILICONE OIL
DO NOT OVERFILL

3) Power connection

Insert the C13 power cable into the C14 socket on the left hand side of the compressor.

Please avoid using any electrical extension leads if possible. However, if you must use a third-party extension lead, this must be as short as possible and must be rated to minimum of 110V / 16A or 230 V / 13 A depending on your local power supply. If unsure, please determine what your local power supply is before operating the compressor.



4) Connecting to a vessel

Connect filling probe to hose, ensure spanner tight or use Quick Release Coupling fitted.



Hill recommends using only fill probes and adaptors which are designed to allow the vessels' integrated non-return valve to close. This allows the moisture collected by the water separator to be drained via the bleed screw on the compressor.

CAUTION:



If using a quick release coupling, always check and make sure the collar on the female quick disconnect is in the forward position and secure on the male fitting you are connecting it to. It is recommended that you check the connection by attempting to pull the female and male ends apart while the fitting is in the forward position before pressurizing.

Connect filling probe to vessel.



Ensure bleed screw is closed (finger tight).

Operating Instructions

Switching on power

Power up the compressor using the red switch on the left hand side. The display will briefly show the Hill logo, the firmware version and the running time.

Next, the compressor will request the user to confirm the lubricant levels have been checked and are correct.



Press the rotary control knob to confirm the lubricant check. After this, the display will show the first page of the main menu; the target pressure display.

Setting Target Pressure

The target pressure is the pressure at which the compressor will automatically stop filling a vessel.

To set the target pressure, first navigate to the "Target Pressure" display. This is the first display in the main menu, which appears after the lubricant check described above.



With the target pressure display visible, press the rotary control knob once to enable selection mode. A selection arrow will appear next to the pressure value. With the selection arrow visible, rotate the rotary control knob clockwise or anti-clockwise to Increase or decrease the target pressure setting.



Once the desired target pressure is displayed, press the rotary control knob once to confirm the target pressure selection. After confirming the target pressure selection, the start display at the end of the main menu will appear.

Starting a fill

First navigate to the start display by rotating the rotary control knob clockwise while in the main menu.

The start display shows the current cylinder block temperature and the selected target pressure.

If the compressor detects that there is high pressure (roughly greater than 70 BAR / 1015 PSI) in the system, this pressure will be displayed on the lower left of the start display. The target pressure is displayed on the lower right.



If no high pressure is detected in the system, only the target pressure will be displayed.



With the start display visible, press the rotary control knob once to start the compressor. After starting the compressor, the running display will appear.

If the pressure in the system is low (roughly less than 70 BAR / 1015PSI), the display will show "Pressurising".



If the pressure in the system is above this, the display will show the current pressure on the lower left side and the target pressure on the lower right.



Pausing a fill

A fill can be paused at any time by pressing the rotary control knob once.

After pausing a fill, rotating the rotary control knob in either direction will cycle between the option to resume or abort the current fill.



Auto Cooling

The compressor is designed to operate within a specific temperature range. The operating temperature range varies depending on the pressure in the system.

The compressor will automatically pause for cooling when it detects that the running temperature has exceeded the maximum operating temperature. This is normal and no operator intervention is required. The compressor will automatically resume after a sufficient period of cooling.

When auto cooling is in progress, the display shows the “cooling” indicator.



Auto Cut-Off & Depressurisation

When the target pressure has been reached, the display will show “Fill Complete”. It is normal for the achieved pressure to reduce by up to 5% after the fill has completed, particularly in smaller vessels. This is due to the effect of cooling and flow losses. To compensate for this, the user may wish to increase the target pressure, permitting that the vessel is sufficiently rated.



DO NOT disconnect the vessel until the compressor has been fully depressurised.



Depressurise the compressor by unscrewing the bleed screw; using a rag for this is advised. Whilst depressurising, some moisture and silicone may be expelled from the water separator. Suitable precautions should be taken to protect any floor coverings under the compressor.

The display will show the progress of the depressurisation.



DO NOT depressurise the system using any other method such as unscrewing the cylinder or using additional bleed screws located at the cylinder.

When the compressor detects that the pressure is low (roughly below 70 BAR / 1015PSI) the display will return to the main menu.

The bleed screw should remain unscrewed to allow the compressor to fully depressurise. After this, the vessel can be safely disconnected.

Lubrication check timeout

During long fills, the compressor will occasionally automatically stop and request that the lubricant levels are checked.

At this time it is also necessary to fully bleed the water separator to prevent excess moisture accumulation. If connected to a vessel without a non-return valve, close the valve on the bottle and bleed the compressor as described above. Users in particularly humid climates may need to bleed the water separator more often.

Setting units of pressure

The unit of indicated pressure used throughout the operation of the compressor is user selectable as BAR, PSI or MPa.

The unit of indicated pressure can be selected on the first page of the settings menu. The settings menu is accessible from the second page of the main menu.



Press the rotary control knob once to enter the settings menu. "set units" is the first page of the settings menu.



Press the rotary control knob a second time to enable selection mode. A selection arrow will appear next to the currently selected unit of pressure.



Rotate the rotary control knob in either direction to cycle between the selectable units. Once the desired unit is visible, press the rotary control knob once to save the selection. The compressor will retain the selected pressure unit, even after being powered off.

To exit the settings menu, rotate the rotary control knob clockwise until "Main Menu" is displayed and press the rotary control knob once.



Trimming Calibration

The compressor is factory calibrated and should accurately sense its internal pressure out of the box. It is however possible that over many hours of use, some pressure sensor drift could occur.

To compensate for the occurrence of slight pressure sensor drift, the compressor features a trim calibration setting. This allows the user to apply a scale and offset to the factory calibration.

Trim calibration is the second page in the settings menu; accessed as described in the previous chapter.



The default settings for trim calibration are 100% scale and 0 BAR offset. It is NOT advised that users change these settings without having observed a consistent inaccuracy in indicated pressure.

Sensor drift is not to be confused with the effects of post-fill cooling as described on page 10.

NOTE: The trim calibration setting should NOT be used to attempt running pressures higher than the maximum operating pressure of the compressor (310 BAR / 4500 PSI). Changes to this setting are recorded and any obvious intentional misuse will void the warranty.

The scale and offset are applied to the TRUE pressure.

For a given target pressure setting:

A scale setting of 105% will increase the achieved pressure by 5%.

An offset of 5 Bar will increase the achieved pressure by 5 Bar.

As an example of how this feature can be used, consider a sensor with a measured drift of +2 BAR at 100 BAR and +4 BAR at 300 BAR (as shown in the table below). To increase the accuracy of this sensor, the following trim can be applied: 101% + 1 BAR.

ACTUAL Pressure	Displayed pressure without trim	Displayed pressure with a trim of 101% + 1 BAR
100	102	100
300	304	300

Troubleshooting

- Compressor will not turn on:

Make sure that the power cable is inserted correctly and that the fuses in the power cable plug and next to the compressor switch are present and functional.

- Pressure does not exceed 50 BAR and/or air escapes from the Pressure Relief Valve (PRV):

With the bleed screw open, run the compressor for 5 mins and then attempt another fill. If the problem persists, contact your retailer.

- Pressure achieved in the bottle is lower than the target pressure:

The differential pressure across the bottle valve and hose, combined with the effects of cooling may cause a small pressure loss. This will differ from one vessel to another. Adjust the target pressure on the compressor to compensate.

- Motor will not start

As a built in safety feature the compressor will not start if the block temperature is extremely low, due to the possibility of internal ice crystals. Thaw the compressor out in a warm room to raise the block temperature.

- Superficial rust on Iron Sleeve

It is normal for superficial rust/discoloration to appear on the external face of the iron sleeve, this will have no impact on the performance or lifetime of the compressor. If the appearance of rust is undesirable, it can be easily removed with emery cloth. Occasional application of a barrier grease, will prevent the rust from appearing.

Shutting the compressor down

Make sure that the cylinder is removed and bleed screw is opened to release pressure. With the motor at rest, turn the compressor off at the switch to the left of the consol.

Storage

Keep upright at all times. Do not store below 5°C (41°F)

Maintenance

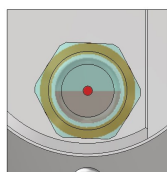

Change crank oil every 50 running hours or once yearly (whichever comes first).

Unscrew sight glass to change Crank Oil (make sure you have a suitable container underneath) and drain.

Regularly check that the Silicone lubrication is free from dirt and debris.

Service kits containing replacements for wearing components are available for specific running time intervals. These intervals are: 50 hours, and 100 hours. The running hours are briefly displayed on the console whenever a compressor is switched on.





Timely servicing is recommended to maximize the longevity of the unit. Heavy users such as clubs, may find that they reach servicing intervals within the warranty period. In this case the services must be carried out in order for the warranty to remain in force.

DO NOT LEAVE THE COMPRESSOR UNATTENDED WHEN IN USE!

**IN THE UNLIKELY EVENT OF MALFUNCION, PLEASE CONTACT THE DISTRIBUTOR FOR AD-
VICE BEFORE ATEMPTING REPAIRS.**

**PLEASE RETAIN THE ORIGINAL RECEIPT OF PURCHASE, AND ANY RECIEPTS FOR SERVICE
KITS PURCHASED.**

**The most up to date version of this manual will be available at: www.airiflepump.com Please check this
website regularly.**

 WARNING	This compressor features 5000psi burst disks for backup over-pressure protection. These burst disks can be replaced with equal or lower pressure burst disks if required but NOT with higher pressure ones. Always ensure appropriate measures are in place to prevent over-pressurisation of vessles.
 DANGER	DANGER OF ELECTRIC SHOCK DO NOT OPERATE OUTSIDE IN THE RAIN DO NOT OPERATE WITH WET HANDS OR WET CLOTHES
 DANGER	PARTS OF THIS COMPRESSOR GET VERY HOT. DO NOT TOUCH THESE HOT PARTS
 WARNING	DO NOT TOUCH MOVING PARTS, FOR EXAMPLE THE COOLING FAN. KEEP FINGERS AND LOOSE CLOTHING AWAY FROM MOVING PARTS
OPERATING TEMPERATURE +5°C to 75°C (41°F to 167°F) THERMAL PROTECTION WILL NOT ALLOW THE UNIT TO START OUTSIDE THIS RANGE	

ERNEST H. HILL LIMITED

LONGACRE WAY - HOLBROOK - SHEFFIELD S20 3FS - ENGLAND

Telephone; +44 (0) 114 248 4882

www.hillpumps.com

sales@hillpumps.com